

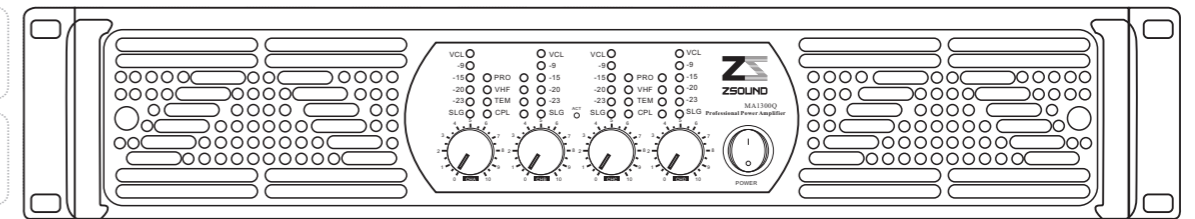

## User's Manual

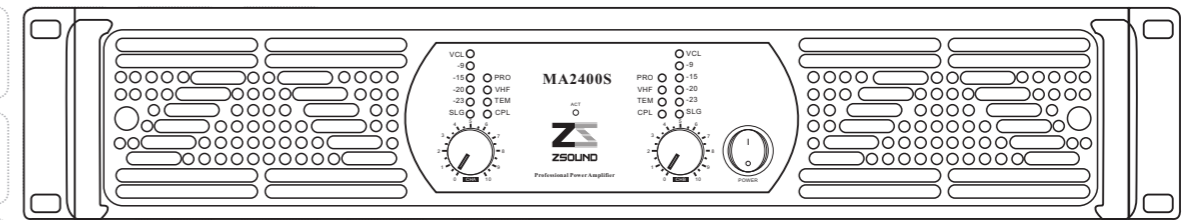

# MA SERIES

(Two/four channel)

## Professional Power Amplifier

Contents..... 1

Important note..... 2

Control elements..... 3

Rear panel features introduction..... 4

Audio input and output connections..... 8

Stereo Mode..... 9

Bridge Mode..... 10

Professional Power Amplifier Specifications..... 11

**WARNING NOTICES**

**SAFEGUARDS**

Electrical energy can perform many useful functions. This unit has been engineered and manufactured to assure your personal safety. Improper use can result in potential electrical Shock or fire hazards. In order not to defeat the safeguards, observe the following precautions for its installation, use and servicing.



**CAUTION**  
RISK OF ELECTRIC SHOCK  
DO NOT OPEN

Explanation of Graphical Symbols



**CAUTION**  
RISK OF ELECTRIC SHOCK:  
OPEN ONLY IF QUALIFIED  
AS SERVICE PERSONNEL

**WARNING:** TO PREVENT FIRE OR ELECTRIC SHOCK, DO NOT EXPOSE THIS EQUIPMENT TO RAIN OR MOISTURE.

**IMPORTANT NOTE**

**ATTENTION:** This unit must be protected from damp because of the risk of fire and the possibility of electric shocks.

1. Make sure that you have the correct mains voltage. Only operate the unit at the mains voltage marked on the rear panel.
2. Make sure that nothing especially no metal objects are inserted into the device. This could result in electric shock or malfunction.
3. If the unit is subjected to extreme fluctuations of temperature e.g. On being transported from outside into a heated room, condensation can form. The unit should not be used until it has reached room temperature.
4. In the event of water or any other fluid being accidentally spilt on the unit switch the unit off immediately and send it to a qualified service workshop for inspection.
5. Make sure that the unit is always well ventilated and never exposed to direct sunlight
6. Do not use sprays to clean the unit as they have a detrimental effect on the unit and could ignite suddenly.
7. The machine use single power switch, please cut off the power before fix.
8. Please do not put the cup, vessel of flower or container above the machine, In case the leak out water then cause the leakage current off the machine.

**Front panel**

The front panel LED area includes the following indicators per channel:

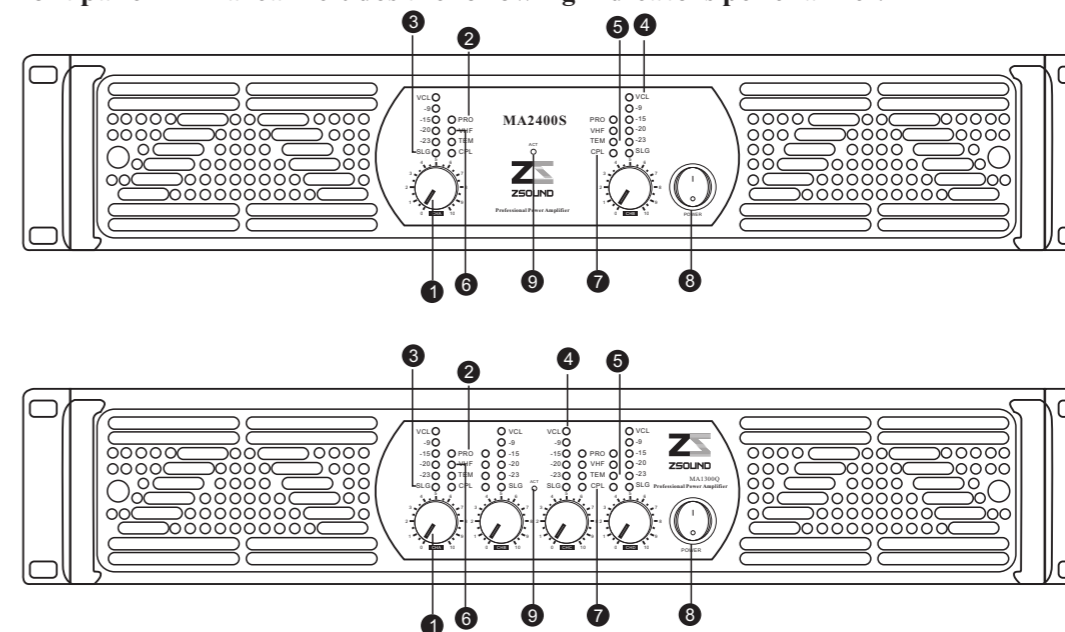

**1. LEVEL CONTROL**

Calibrated detente potentiometers to alter the total gain of the power amplifier. In order to avoid distortions in mixing consoles upstream, these controls should normally be positioned between 0 and 10. The calibrated markings show the additional attenuation directly.

**2. PROLED**

Auprotection under mute position.

**3. SIG / HI-IMPLED**

Green SIG Indicates output signal levels in normal operating range  
Hi-imp-High-impedance/open load detected (Orange)

**4. Limit power LED**

When this LED lights up, the Limit power function is working.

**5. TEMP**

This LED lights up if the limiter has been activated and the power amplifier is being operated at the clip level. If the LED flashes briefly, this is not a cause for concern. If this LED is lit permanently, the volume should be reduced to avoid overload damages to the connected loudspeaker systems.

**6. VHF**

VHF-Very High Frequency protection active (output muted) (Yellow constant)

**7. CPL LED**

CPL-(Orange constant with output muted): Low impedance/short circuit detection fault

**8. POWER Switch/LED**

Turn the unit power on (lights up) or off (lights out).

**9. Output in dic ation**

This LED lights up if a signal is present at the power amplifier output. The indicator goes off when the speaker line has shorted or a protective circuit has been activated thus indicating that there is no signal at the speaker output terminals.

## Rear panel features introduction

### MA2400S

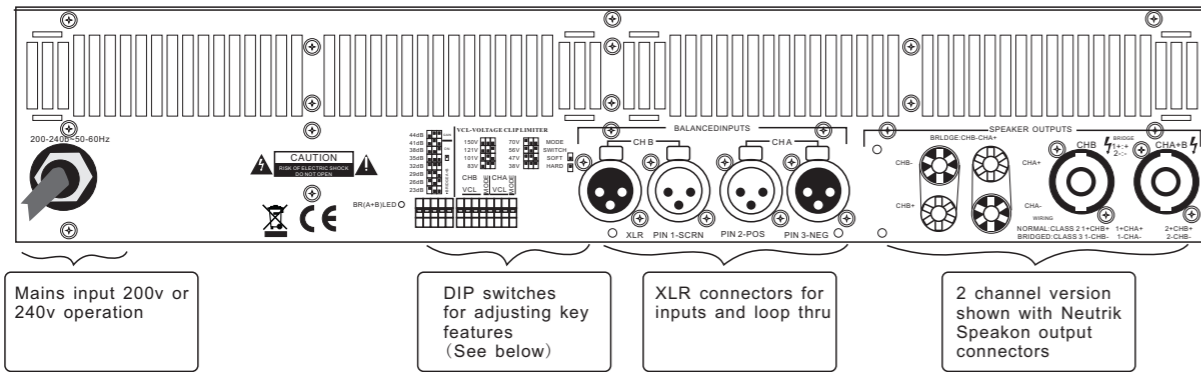

Mains input 200v or 240v operation

DIP switches for adjusting key features (See below)

XLR connectors for inputs and loop thru

2 channel version shown with Neutrik Speakon output connectors

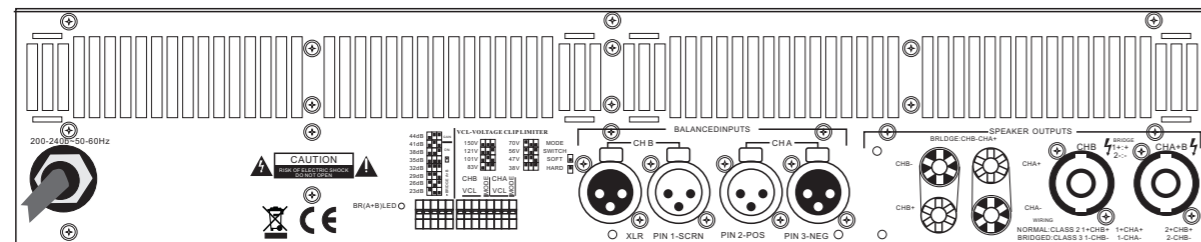

Rear view of 2 -channel model fitted with Speakon connectors

**!** Two -channel model shown .Two -channel versions have VCL and Bridge Mode switches for channels 1 and 2 only .All models have different VCL values Functions are otherwise identical .

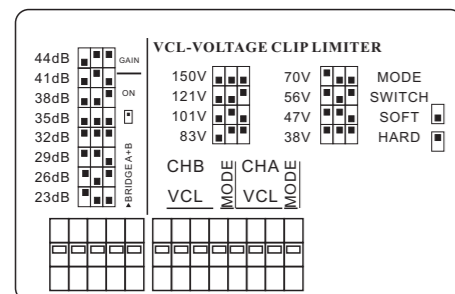

6 2 1 The DIP switch features  
The following features may be adjusted using the DIP switches on the rear-panel of the amplifier .Gain - Globally set for all channels , from 23dB to 44dB in 3 dB steps .

Bridge 1  $\mathcal{B}$  Switches the channel pairs into bridge mode operation An automatic 6 dB gain compensation is applied .

## Rear panel features introduction

### MA1300Q

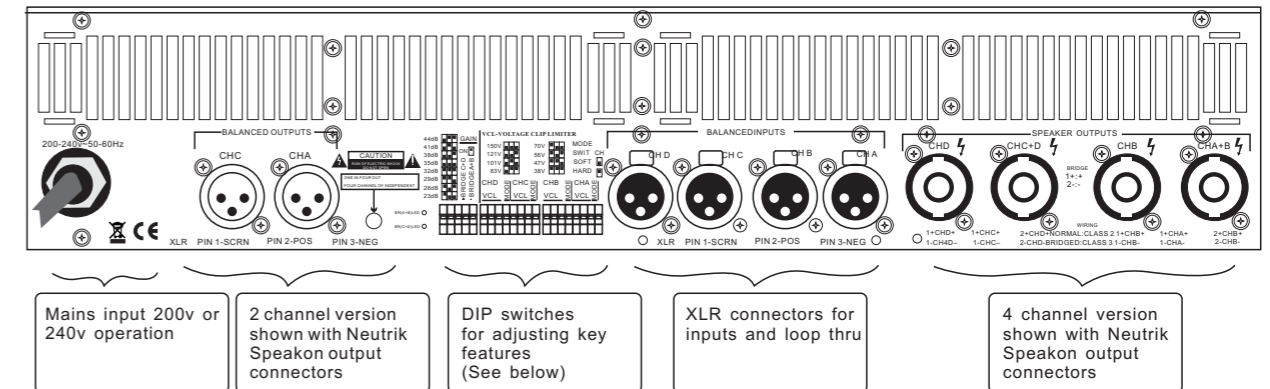

Mains input 200v or 240v operation

2 channel version shown with Neutrik Speakon output connectors

DIP switches for adjusting key features (See below)

XLR connectors for inputs and loop thru

4 channel version shown with Neutrik Speakon output connectors

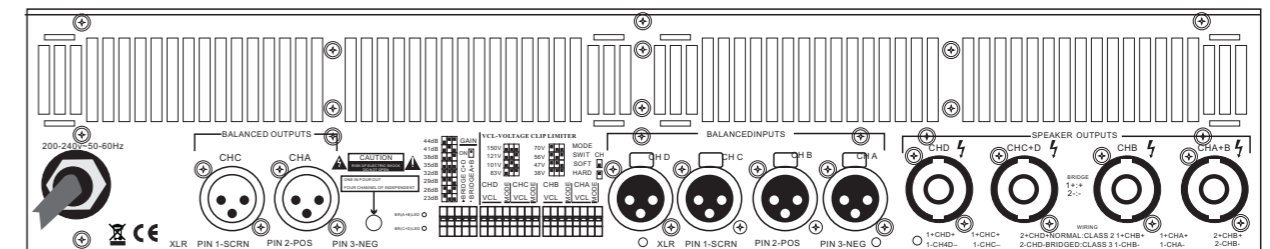

Rear view of 4 -channel model fitted with Speakon connectors

**!** Four -channel model shown .Two -channel versions have VCL and Bridge Mode switches for channels A and B only .All models have different VCL values Functions are otherwise identical .

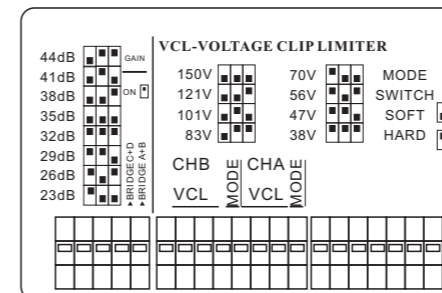

6 2 2 The DIP switch features  
The following features may be adjusted using the DIP switches on the rear-panel of the amplifier .Gain - Globally set for all channels , from 23dB to 44dB in 3 dB steps .

Bridge A  $\mathcal{B}$  and C +D Switches the channel pairs into bridge mode operation An automatic -6 dB gain compensation is applied

VCL		OLTAGE		LCP		M ITER	
MA2400S				MA1300Q			
196V	90V	150V	70V				
158V	72V	121V	56V				
130V	60V	101V	47V				
108V	52V	83V	38V				

VCL Voltage Clip Limiter adjustment is provided for eight discrete levels for each channel for each channel . Select the setting most appropriate for connected speakers .

VCL- in	Mode	Voltage	Limit
MA2400S	MA1300Q		
392V	300V		
316V	242V		
260V	202V		
216V	166V		
180V	140V		
142V	112V		
120V	94V		
104V	76V		

Mode Select VCL mode to either Hard or Soft operation . For channels driving sub-woofers and low-frequency drivers ,it is recommended to use the Hard setting for optimal operation . For mid- and high-frequency drivers always select Soft .

Output connectors

Input or output connectors

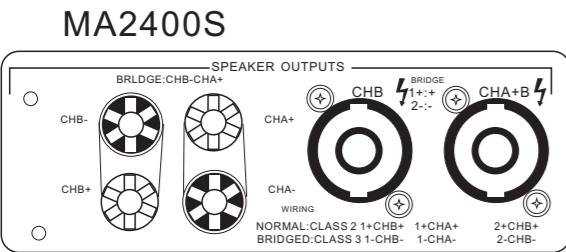

Speakon outputs—2—channel models

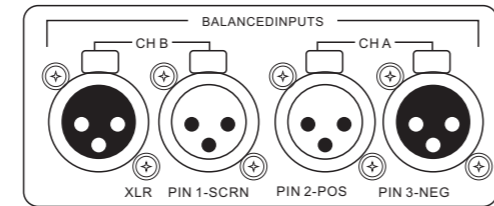

Audio inputs or output- 2 -channel models

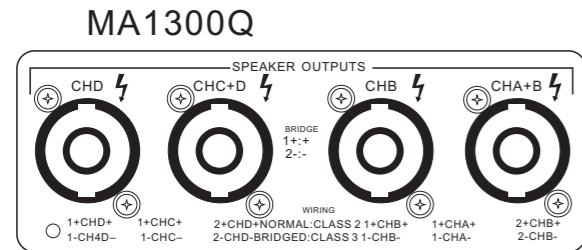

Speakon outputs—4—channel models

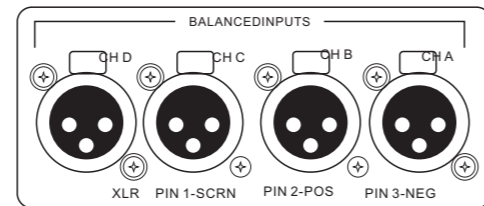

Audio inputs - 4 -channel models

MA2400S

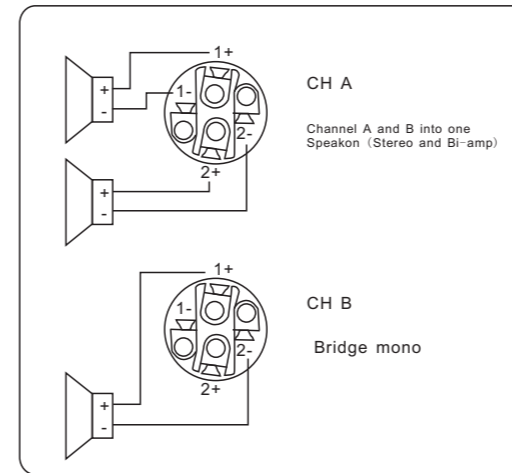

Two—channel amplifiers Additional connectors are provided for Channel 1.

MA1300Q

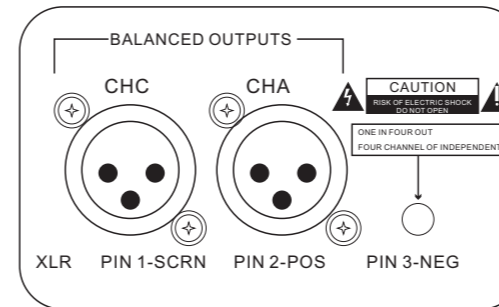

Link outputs PARALLEL or STEREO models: In stereo models, the signal input into channel A can be output from channel A only, similarly, the signal channel C is the same. In parallel models, the signal input into channel A or channel C can be output from channel A and channel C

Link outputs ONE IN FOUR OUT or FOUR CHANNEL OF INDEPENDENT models

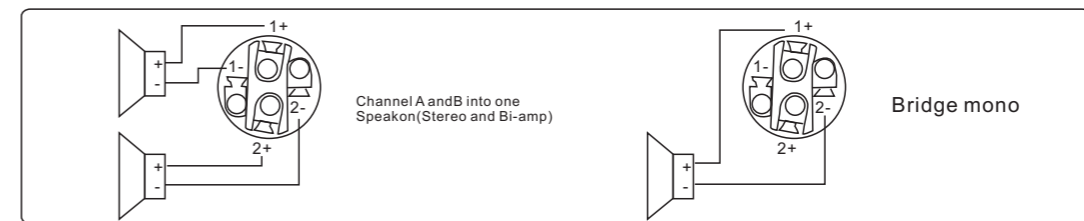

Four-channel amplifiers Additional connectors are provided for channel C and channel D. channel C functions as channel A above, and channel D as channel B above



BALANCED INPUT CONNECTIONS

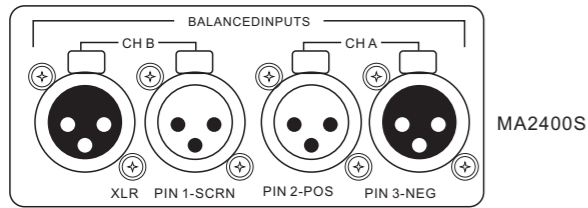

Audio inputs - 2-channel models

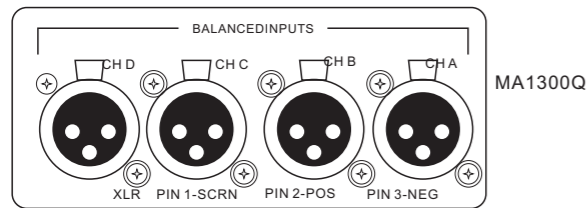

Audio inputs - 4-channel models

The XLR input connectors are electronically balanced, and wired according to the IEC 268 standard (pin 2= hot). XLR input connectors should be wired as follows:

- Pin 1 Ground/shield
- Pin 2 Hot (+)
- Pin 3 Cold (-)

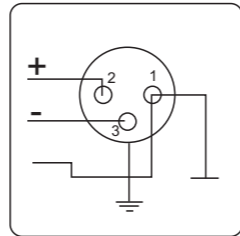

When linking the same source signal to several input channels, be aware that there is a limit to the number of channels an output source can "drive". A typical output source (e.g. a DSP crossover unit) can drive up to two or four amplifier channels before external line-drivers might be required to buffer the signal.

Unbalanced Input connections

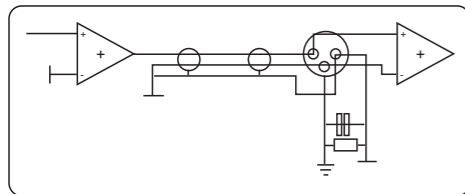

To connect an input to an unbalanced source, it is possible to connect pins 1 and 3 in the XLR plug at the amplifier end of the cable. However, a better method is to connect pin 3 to the shield at the source and of the cable, as this usually results in better hum and noise rejection. Balanced input connections are recommended whenever possible.

Speakon Output connections

Refer to the instructions in this section if your amplifier is equipped with the Speakon output connectors.

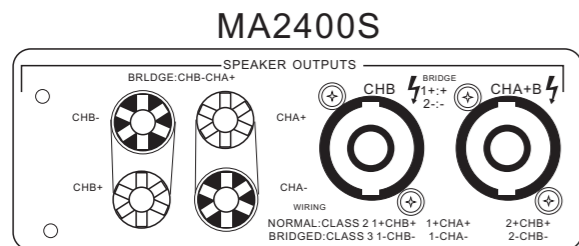

Speakon outputs - 2-channel models

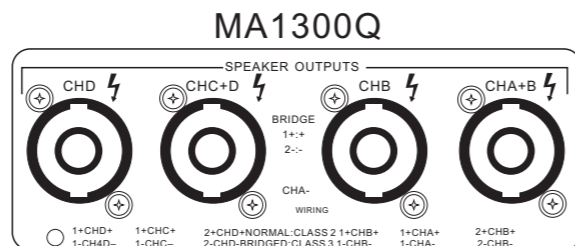

Speakon outputs - 4-channel models

MA2400S

Before setting the mode, please turn off the amplifier and slide the mode select switch to below (Picture 1). In this mode, Channel 1 and Channel 2 operate independently (just traditional stereo amplifier). The signal input into channel 1 can be output from channel 1 only, similarly, the signal input into channel 2 can be output from channel 2 only. The many channels, one by one in order type pushes.

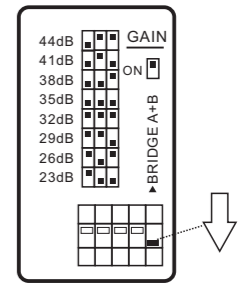

(Picture 1)

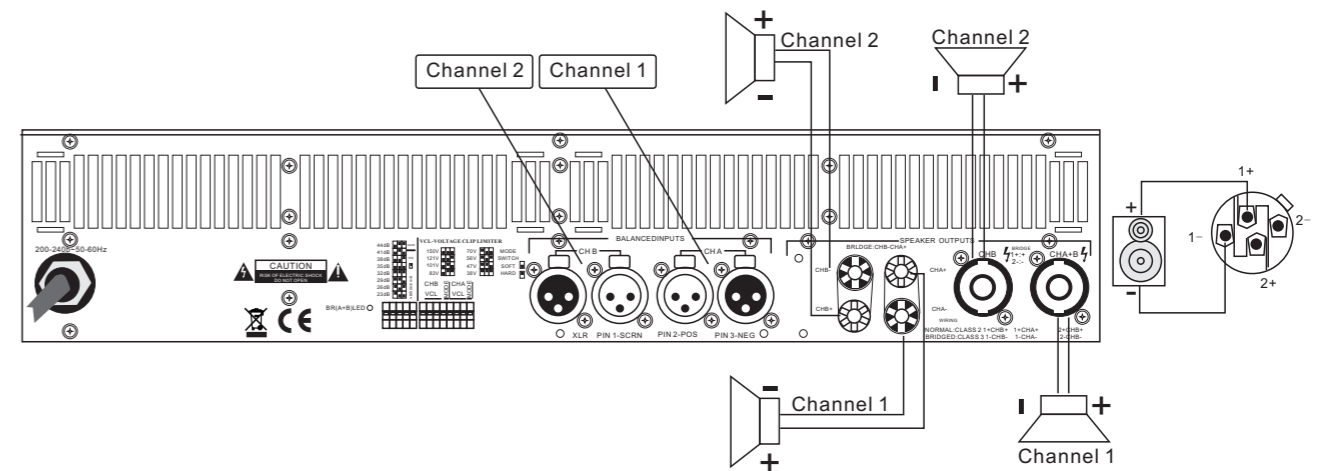

MA1300Q

Before setting the mode, please turn off the amplifier and slide the mode select switch to below (Picture 2). In this mode, Channel A and Channel B operate independently (just traditional stereo amplifier). The signal input into channel A can be output from channel A only, similarly, the signal input into channel B can be output from channel B only. The many channels, one by one in order type pushes.

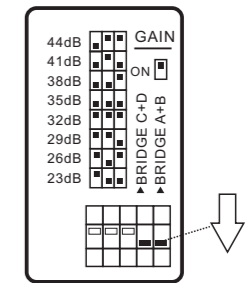

(Picture 2)

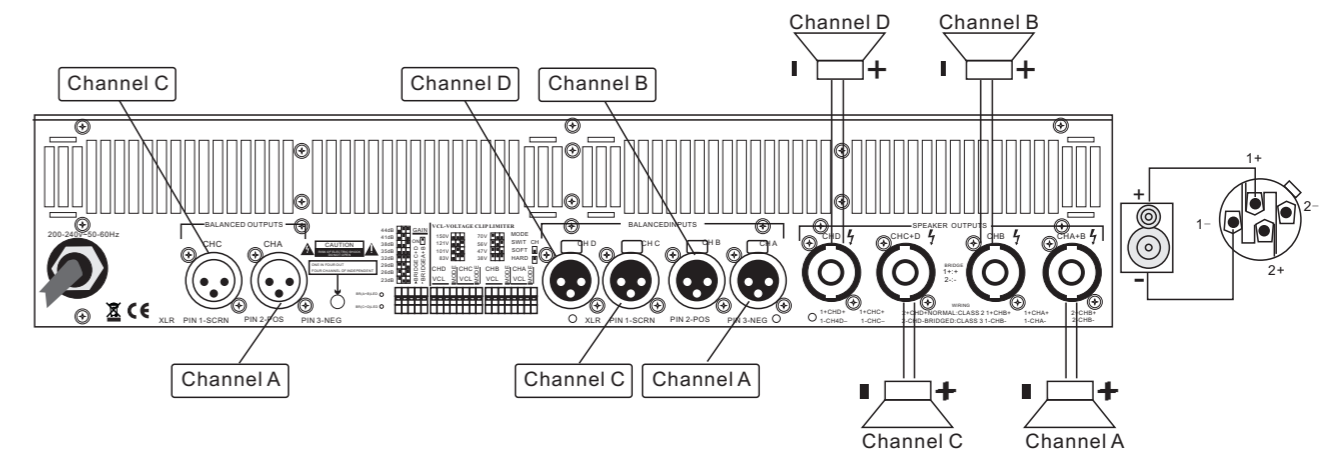

MA2400S

Before setting the mode , please turn off the amplifier and slide the mode select switch to above (Picture 3), channel 1 and channel 2 are bridged. At time , the signal input into channel 1 will be output from the bridge and. On other hand , the output level control of channel 2 should be turn down to smallest . Only the volume control of channel 1 are used to control the volume of whole system.

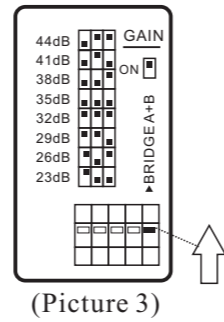

(Picture 3)

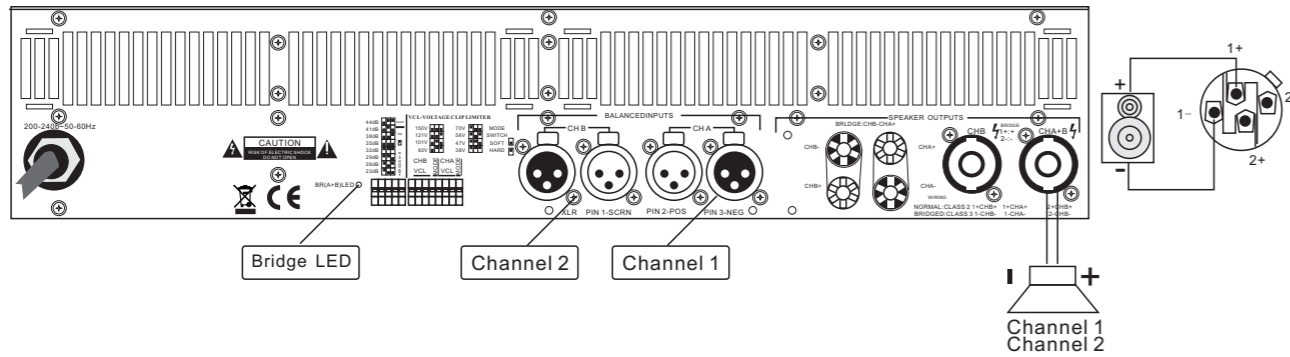

MA1300Q

Before setting the mode , please turn off the amplifier and slide the mode select switch to above (Picture 4), channel A and channel B are bridged. channel C and channel D are bridged. At time , the signal input into channel 1 will be output into channel A and channel C will be output from the bridge and. On other hand , the output level control of channel B and channel D should be turn down to smallest . Only the volume control of channel A and channel C are used to control the volume of whole system.

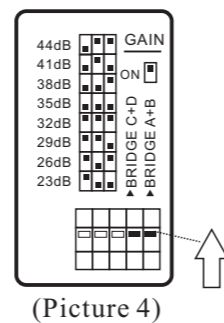

(Picture 4)

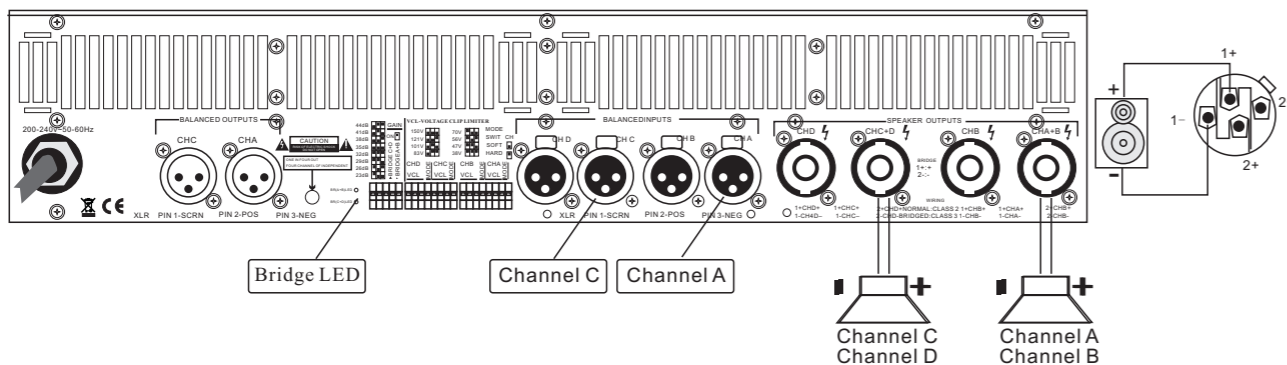

Model	MA2400S	MA1300Q
<b>Output Power</b>		
8 Stereo Power	2x2400W	4x1300W
4 Stereo Power	2x4000W	4x2200W
8 Bridged Mono Power	8000W	2x4400W
4 Bridged Mono Power	12000W	2x4800W
<b>FREQUENCY RESPONSE</b> 20Hz -25kHz±0 5dB		
THD +N (Rated power 4 KHz )%	0.1%	
Signal Noise Ration(dB)	110dB	
Amplifier gain selectable (all channel)-real-panel switches	23 26 29 32 35 38 41 44dB	
<b>Connectors</b>		
Input connectors(per ch.)	3-pin XLR,electronically balanced	
Input Impedance	20K Balanced/10K Unbalanced	
Output Connectors	Speakon Connectors(Neutrik)	
<b>Power</b>		
Power Requirement	200-240V~50-60Hz	
Minimum power-up voltage.220V	180-260V~50-60Hz	
<b>Dimension</b>		
Airframe	483×377×88mm	
Weight		
Weight(net)	13Kg	